

## A Quick Start Guide to Observing Meteors by radio

At an altitude of 100km meteors burn up creating an ionised trail reflective to radio. The UK meteor beacon, call sign GB3MBA, located at the Sherwood Observatory of the Mansfield and Sutton Astronomical Society "illuminates" a region with a diameter of more than 400km at this altitude so that radio echoes from meteors entering the Earth's atmosphere above a large part of the UK can be detected using suitable receivers. See <https://ukmeteorbeacon.org/Home>

The aim of this document is to describe an inexpensive and easy way of observing radio echoes from meteors. In addition to being a useful way to study meteors this is a great STEM project to introduce Radio techniques and Astronomy. Suitable Software Defined Radio receivers are available from from £12 to £40 and more sophisticated ones for £200 or more.

### What will you'll need ?

You will need a PC with a spare USB port and the following:-

#### An antenna

Start with a dipole which can be made from wire and some coax cable.

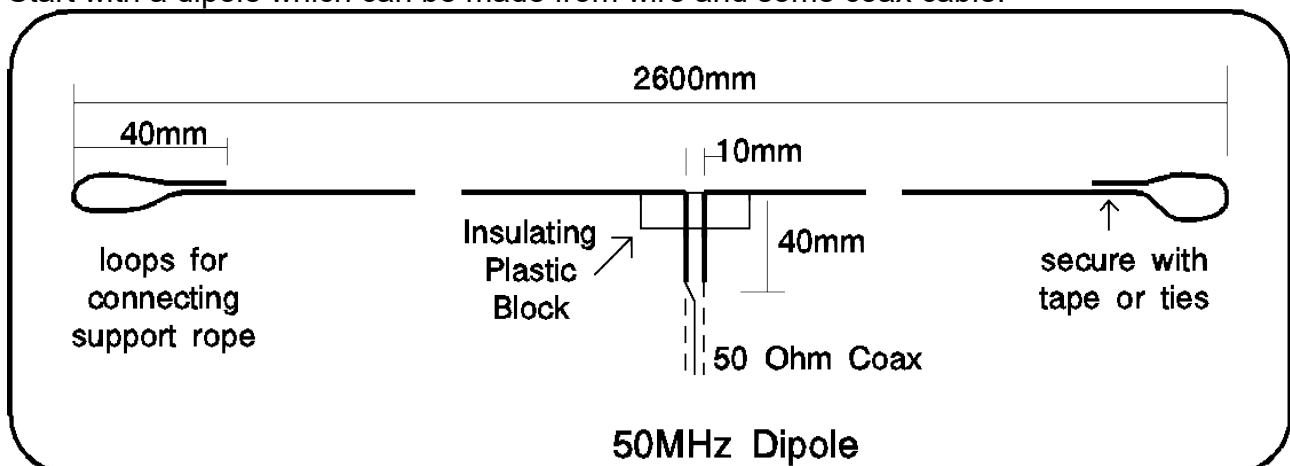

Fig 1

75 Ohm TV cable will do if you don't have access to 50 Ohm cable. String the antenna up outside if possible, as far from interference sources as you can. If you can't put it up outside try the loft space if available. If making the antenna is too big a challenge try to contact your nearest amateur radio club to see if they or one of their members can help. You can find your nearest club here:- <https://rsgb.org/main/clubs/club-finder/> or at [https://www.dxzone.com/catalog/Ham\\_Radio/Clubs/Europe/UK/](https://www.dxzone.com/catalog/Ham_Radio/Clubs/Europe/UK/).

A better antenna which can also be made cheaply from wire is the Moxon antenna which is described here:- <https://g1ybb.uk/easy-building-of-a-moxon-antenna-with-4nec2/> ( Ref 1 ) This web page includes a calculator for the antenna dimensions. Enter the required frequency which is 50.408MHz and the diameter of the wire, rod or tube you plan to use.

## A Software Defined Radio



Fig 2

Software Defined Radios are ideal for receiving the meteor echoes from the GB3MBA beacon. They come in all sorts of shapes sizes and costs.. The lowest cost solution is an RTL Dongle such as in Fig 2.

<https://www.rtl-sdr.com/rtl-sdr-quick-start-guide/>

You will need to connect your antenna to the SDR you are using. With the example in Fig 2 you will need a cable with an SMA connector.

There are many more sophisticated SDRs available but at higher cost. The Fun Cube Dongle Pro Plus is one. We are developing a receiver network that will stream data via the internet and we hope that some folk will want to build their own receivers and join them into our network. We plan to use the RSPdx from SDR Play as it provides better resolution and can be locked to a GPS reference for precise frequency / Doppler measurements which are needed for more detailed studies. So if you plan to contribute your observations to the network the RSPdx is recommended.

If you want to make meteor observations by radio but cannot deploy your own system you can use the data stream from the receiver network at:-

<https://ukmeteorbeacon.org/beaconclient/>

## Control and Display Software

A convenient way to observe meteor echoes is with a waterfall display see screenshot 1. The upper portion of the display shows spectrum with frequency as the horizontal scale and amplitude as the vertical scale. The lower portion is the waterfall display which shares the same horizontal frequency scale as the spectrum display and with time flowing down. The strength of echoes is represented by brightness. You'll need some software to control the SDR and display the echoes. I recommend SDR Console which is free from <https://www.sdr-radio.com/Console> but do make a donation for to feed Simon's dog if you can! You'll need to load the definition for your radio e.g. RTL Dongle and follow the instructions to set it up. More details at <https://ukmeteorbeacon.org/documents/SDRconsolebasicSDRrecieversetupV2.2.pdf> .

There are other SDR display software options including SDR# (SDR Sharp ) see <https://www.rtl-sdr.com/sdrsharp-users-guide/> and SDRUno see <https://www.sdrplay.com/sdruno/>. If you prefer to use these and find them suitable please share your experiences at [ukmeteorbeacon.org](https://ukmeteorbeacon.org).

These notes assume you are using SDR Console. Take some time to familiarise yourself with the controls including contrast, brightness, display speed etc. Set the frequency to 50.408MHz and Span to +/-500Hz AGC OFF and the waterfall rate to ( say ) 5 in the view menu. You'll need to set the Gain ( usually to maximum) in the Home menu. Find and adjust the scale sliders by moving the pointer to the upper right hand part of the spectrum display and the contrast slider at the right hand side of the waterfall display. You can see some of the settings in Screenshot 1 along with a meteor echo of the kind you can expect to see.

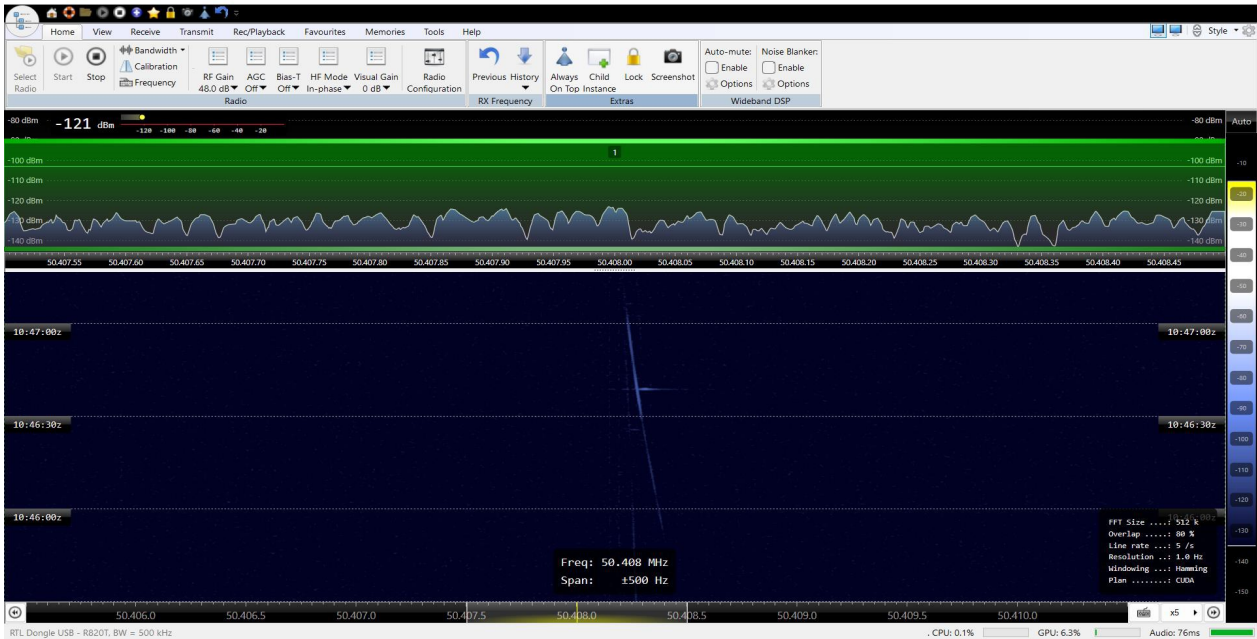

Screenshot 1 RTL2023-04-02-114716

Screenshot 1 was recorded at a distance of about 200km from Mansfield using the RTL dongle (Fig 2) and a Moxon antenna. The near vertical line is an aircraft reflection and the almost horizontal line is an echo from a meteor probably no bigger than a grain of sand but briefly leaving a much larger ionised region reflective to radio as it burns up. If you live within about 400km of the beacon you can expect to see aircraft reflections along with meteor echoes but as aircraft generally fly at an altitude of less than 10km the range of aircraft echoes does not usually exceed 400km. If you are within 200km of the beacon and using a directional antenna such as the Moxon ( Ref 1 ) then point it upwards and end on to the beacon to reduce the direct signal to a minimum.

Now you are ready to start Observing Meteors using echoes from the GB3MBA beacon transmitter.

If you increase the frequency span to +/- 2.5KHz and the waterfall speed to say 20 you can display more detail of individual echoes although you will need to be patient to catch individual meteor events as the waterfall display moves more quickly.

If you are quick you can capture screen shots like screenshot 2 which shows the rapidly changing Doppler shift as the meteor decelerates AND as the reflection Path changes. Sometimes the meteor will appear to accelerate but this is an illusion caused by the reflection path extending.

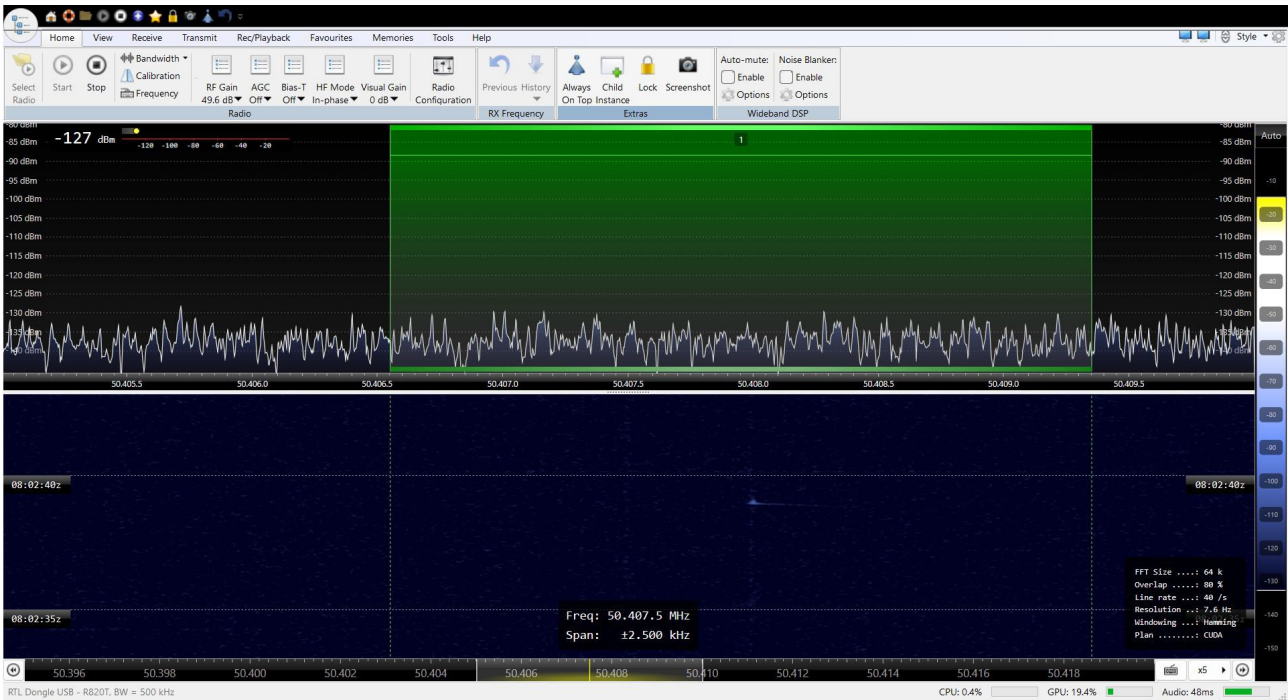

Screenshot 2 RTL-2023-03-20-080242 image rather feint.

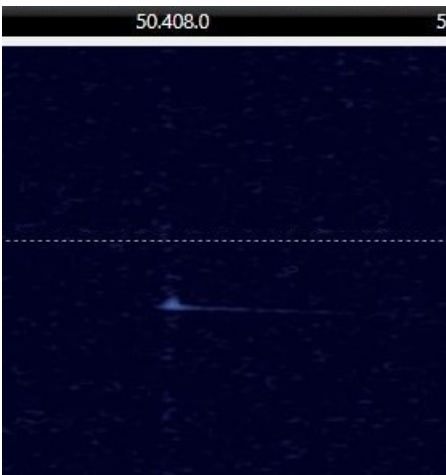

Screenshot 2 Enlarged

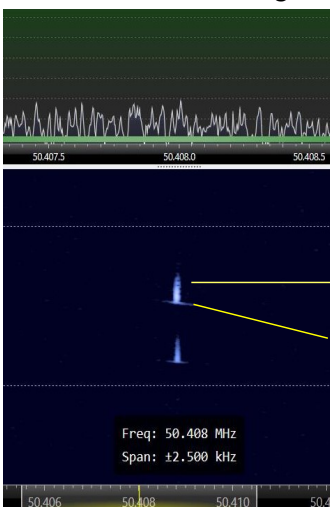

Screenshot 3

Screenshot 3 shows two meteor echoes with head and tail echoes. The head echo is from the rapidly moving meteor exhibiting a rapid change in frequency due to the Doppler Shift changing as the reflection path changes and the meteor decelerates due to friction.

Tail ..... remember time flows down so the head comes first.

Head

The tail echo is from a region that has become sufficiently ionised by the passage of the hot meteor to become reflective to radio for a longer period which can extend from seconds to minutes and is static, suspended in the atmosphere, so exhibits little or no Doppler shift. Any Doppler shift is due to wind.

## ***What can possibly go wrong !***

The bane of all radio astronomers is man made noise / interference. The first thing you should do is to assess the noise level at your location and to find the best position and orientation for your antenna. Follow the instructions in the Observing notes at :-

<https://ukmeteorbeacon.org/Observing> .

You can check your local radio noise level using a simple and very low cost antenna such as a dipole made from wire. ( Fig 1 ). Dipoles have a deep null at both ends of their axis with the maximum signal at right angles to the axis of the wire. This null can be used to reduce the direct signal or to reduce a strong local interference source.

A more directional antenna such as the Moxon ( Ref 1 ) or a Yagi antenna may help by “nulling out” an interference source. Pointing the main lobe of the antenna up towards a point 100km above Mansfield is recommended and may also help reduce local interference.

If you are within about 400km of the beacon you can expect to see aircraft echoes and possibly a direct signal from the beacon as well as meteor echoes.

If all else fails, use the live streams at <https://ukmeteorbeacon.org/beaconclient/> where you can see echoes received by up to 6 receivers in the network. Their data, with greater bandwidth, including precision timing, is being recorded for research purposes. See Screenshot 4.

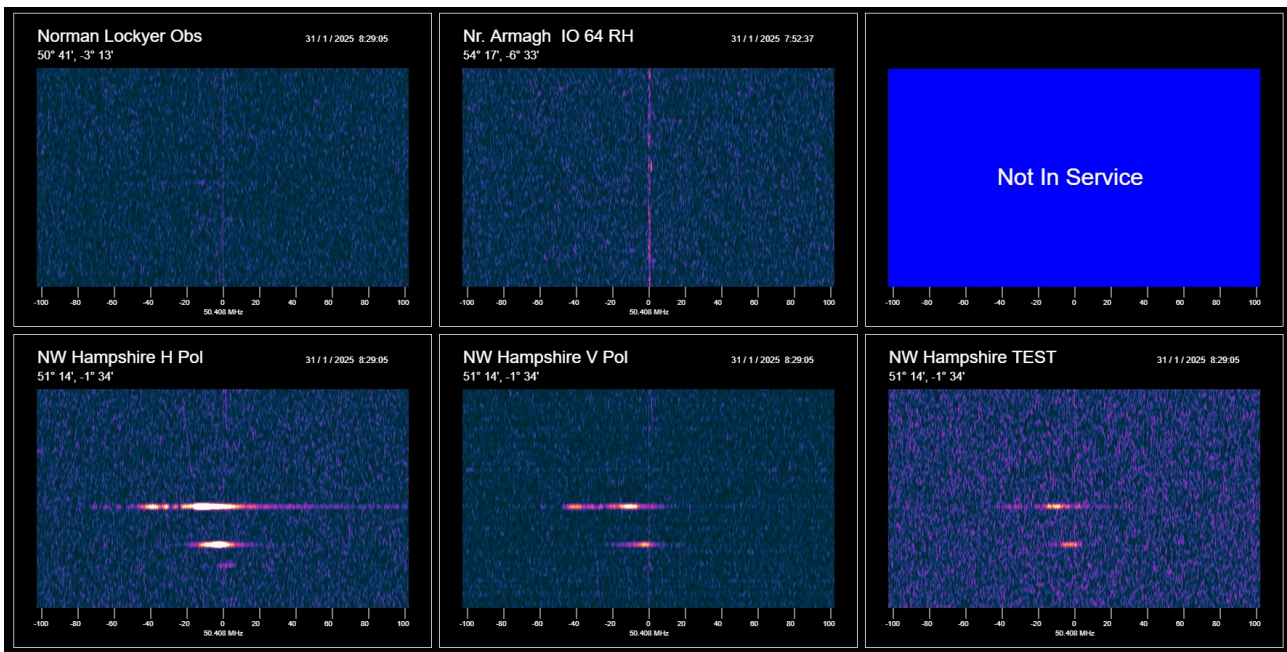

*Screenshot 4*

This project is supported by the Radio Society of Great Britain and the British Astronomical Association, to promote studies into meteor events over the UK. Watch <http://ukmeteorbeacon.org/Home> for updates on the project.